



Product Data Sheet

TS8100 Series

Positive Displacement

PC Pump

The TS8100 Series Positive Displacement Pump is a continuously volumetric dispense pump based on Progressive Cavity (PC) technology. The pump is designed to dispense a wide range of fluids, from low viscosity coatings to high viscosity greases.

Techcon's PC Pump uses a special stator and rotor design to provide consistent dispensing output.

The turning rotor moves the fluid in tightly sealed cavities through the stator's fluid chambers to create a volumetric fluid flow that does not change the shape or size of the fluid. Due to the PC Pump's unique dispensing technology, accuracy and repeatability of $\pm 1\%$

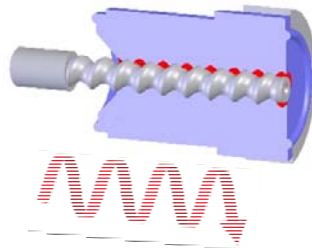

INCLUDED WITH THE UNIT

- Syringe bracket
- Mounting bracket kit
- Luer lock fitting
- Cleaning kit
- Dispensing tip selection pack

TYPICAL APPLICATIONS

- Under filling PCBA components
- Encapsulation and Potting applications
- Applying lubrication on Automotive parts
- Dispensing pastes and flux

KEY FEATURES AND BENEFITS

- Volumetric, positive displacement
- Accurate and repeatable up to $\pm 1\%$
- No dripping with any viscosity fluid
- Compatible with abrasive materials
- Does not damage or break fillers
- Easy to clean

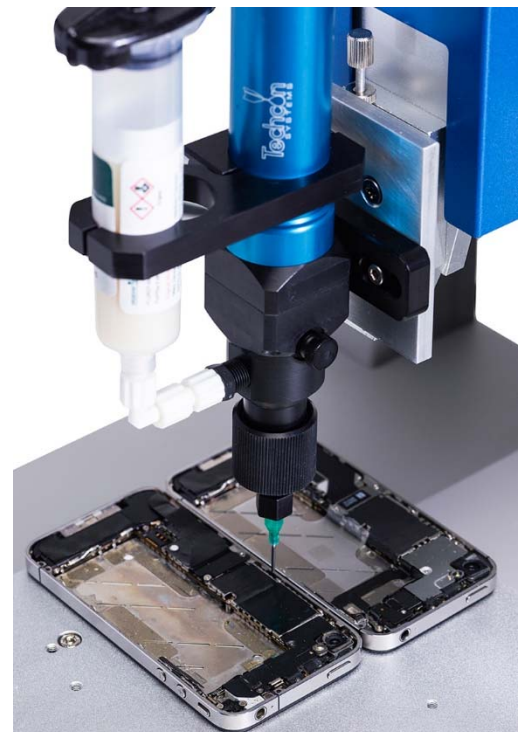

TYPICAL SETUP

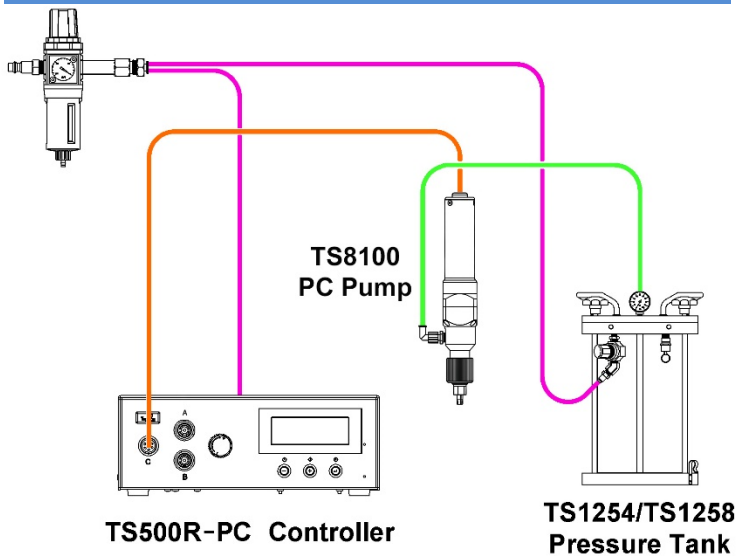

— FLUID
— CONSTANT AIR
— MOTOR CORD

SPECIFICATIONS & PART NUMBERS

Part Number:	TS8100-100
Size (Imperial):	8.1" Length x 1.34"
Size (Metric):	205.7mm x 34mm
Weight:	13.4 oz (380g)
Fluid Inlet Port:	1/8" NPT female
Fluid Outlet Port	Luer taper and cap
Motor:	24 vdc
Dispensing Volume Per Rotation:	0.012ml average
Flow Rate :	0.15 – 1.04 ml/min
Min. Dispense Amount:	0.001ml
Precision ± Absolute:	± 1% (1)
Self-Sealing:	2 bar (2)
Direct Mount:	3 – 55ml Syringe
Mounting Port:	M5
Viscosity Range:	1 – 300,000cps
Wetted Parts:	Acetal, SS*, PFE*, UHMWPE

- (1) Volumetric dispensing as absolute deviation per complete revolution and also depends on dispensing fluid.
- (2) For fluid with viscosity of 1000 Cps or lower. The pump can handle up to 5.5 bar for 300K Cps viscosity fluid.

ACCESSORIES

- **XYZ Robot:** Techcon's Bench-Top Dispensing Robots makes it easy to automate fluid dispensing.
- **Fluid reservoirs:** The pump can be fed from the TS1254 (1.8 litre) or TS1258 (5 litre) Pressure Tank, or from any size syringe barrel or cartridge.
- **Digital Controller:** Techcon's TS500R-PC Digital Controller is designed specifically for Techcon's TS8100 PC Pump.



LOCAL DISPENSING SOLUTIONS WORLDWIDE

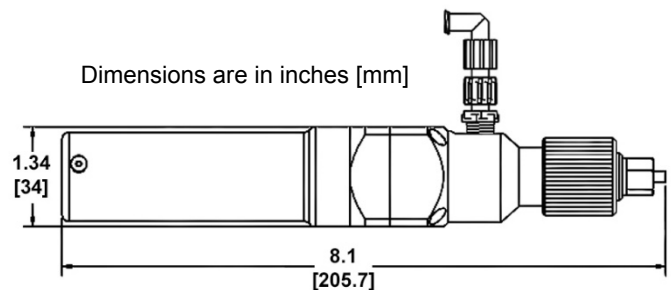
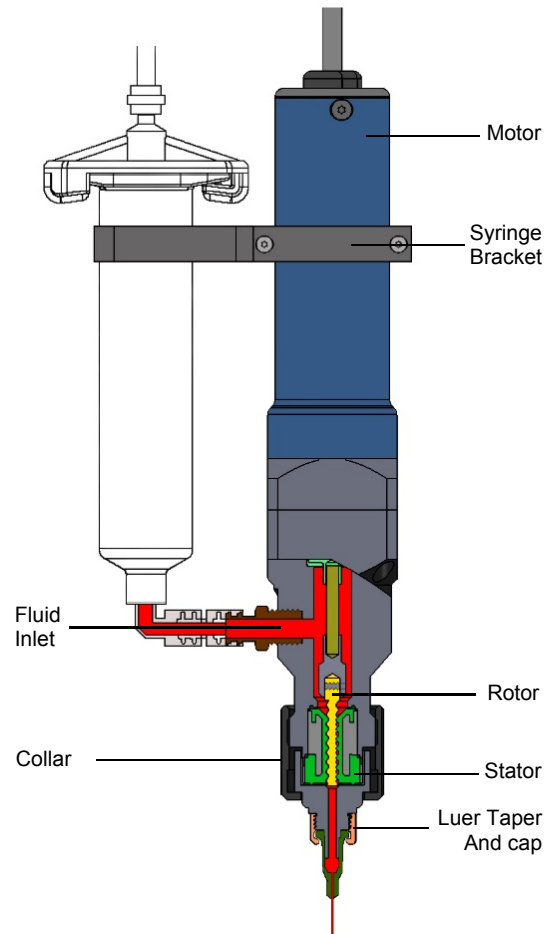

For Sales and Support:

Techcon Systems Corporate Headquarters,
10800 Valley View Street, Cypress,
California, 90630, USA.

Tel: 1-714-230-2398, Fax: 1-714-828-2001

E-mail: oemorders@okinternational.com

Techcon Systems European Corporate Office,
Eagle Close, Chandler's Ford Industrial Estate,
Eastleigh, Hampshire, SO53 4NF, UK.

Tel: +44 2380 489 100, Fax: +44 2380 489 109

E-mail: europa-orders@okinternational.com

Or visit www.techconsystems.com

*SS: Stainless Steel

*PFE: Perfluoroelastomer

*UHMWPE: Ultra High Molecular Weight Polyethylene