

SilverTape 5310

TRANSPARENT DIRECT FOAM

Product Information 01.2015

1/2

SilverTape 5310

Is a double sided high performance acrylic based adhesive tape, which is especially designed for the bonding of high and medium energy surfaces as well as various transparent plastics where a highly transparent bond is required and no stress corrosion may occur. Due to their conformability they are capable of bonding a variety of different thin and structured materials full surface and tension free. The tape is capable of absorbing the differing thermal expansions of the two different materials. Important is to avoid stress and tension on the bond during application. More advantages: vibration dampening, very good sealing properties, very good resistance to weathering, aging, yellowing (UV influence), chemicals, plasticizers, resulting in excellent long term stability.

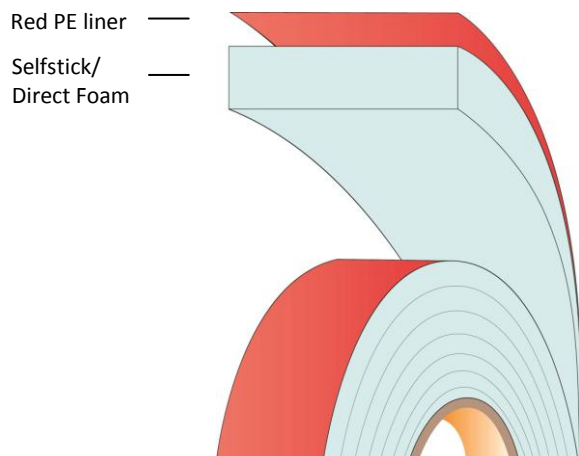

| | |
|-------------------------|--|
| Thickness: | 1,0 mm (0.039 inch) ± 10% |
| Core: | Closed cell acrylic |
| Adhesive: | Closed cell acrylic |
| Density: | 900kg/m ³ (56lb/ft ³) |
| Color: | Transparent |
| Liner: | Red PE liner or white paper liner |
| Solvent Resistance: | Excellent |
| UV Resistance: | Excellent |
| Temperature Resistance: | |
| Minimum | -40°C (-40°F) |
| Short term | 160°C (320°F) |
| Long term | 100°C (212°F) |

| | | | |
|------------------------|---|--|-------------|
| 90° Peel Adhesion | N/10mm (lb/in) | 33 (18) | ASTM D3330 |
| Dynamic Shear Strength | kPa (lb/in ²) | 520 (75) | ASTM D-1002 |
| Normal Tensile | kPa (lb/in ²) | 590 (85) | ASTM D-897 |
| Static Shear Strength | Grams Weight that ½ square inch will hold 10,000 minutes (7 days) | 22°C (72°F) 1000 66°C (150°F) 500 93°C (200°F) 500 121°C (250°F) 177°C (350°F) | ASTM 3654 |

Suitable for:

- high and medium surface energy plastics, transparent plastics, stainless steel, galvanized, anodized aluminum, coated aluminum, glass*

Available sizes:

- jumbo: 500mm x 330 meters (core 3")
- log: 500mm x 33/66 meters (core 3")
- slit roll: 4 – 250mm x 33/66 meters (core 3")
- spool roll: 5 – 25mm x max 1000 meters (core 6")

SilverTape 5310

TRANSPARENT DIRECT FOAM

Product Information 01.2015

2/2

Application Guidelines

Every good bond starts with proper surface preparation. This preparation consists of several steps, such as cleaning, abrading, applying pressure, the use of a primer and the right working environment. It is important to ensure your work area to be clean and free from dust and contaminants.

A minimum temperature of 15 °Celsius is required.

Cleaning

To clean your light and medium contaminated substrates, AFTC offers the AFTC SilverClean or an isopropanol/alcohol solution (IPA) is acceptable. When cleaning your substrate, a tear free, light colored paper towel is required. Wipe the substrate in one direction using the one cloth method (one cloth with cleaner) or a two cloth method (one cloth with cleaner and one dry cloth to follow) is acceptable if you are short on time. Repeat these steps until your cloth is clean and free of any contaminants. For heavily contaminated substrates, use a cleaning agent such as MEK, Heptan or Acetone. These cleaning agents may leave a residue, which would have to be removed using the IPA cleaner.

Abrasion

When bonding to raw aluminum, abrading of the surface is a must. The oils used in the waltzing of the aluminum are pressed into the pores of the material. To remove these oils, that will influence the bond, we recommend using the AFTC SilverPads. These abrasive pads ensure the proper level of abrasion without damaging your substrates. Besides raw aluminum, abrading is a method utilized to help improve your bond. After the abrasion process is completed, remove any residue using an IPA cleaner following the methods mentioned above.

Primer

The use of a primer is recommended when bonding to some low surface energy substrates. Examples include, different types of polymers, powder coated metals, or porous materials such as wood, cork, stone or concrete.

Primers are also used to help speed up your production process. The AFTC SilverTape line can take up to 72 hours to reach its end-strength. The use of a primer ensures the end-strength will be achieved within 20 minutes.

AFTC offers two primers; the primer 33 and the primer 101. Determining which one of these primers is suitable for your application ultimately depends on the substrates and environmental influences. Your AFTC technical support will gladly advise you which primer to use.

Pressure

AFTC SilverTapes are pressure sensitive adhesives. Therefore, a minimum amount of pressure is required on the bond line to ensure the maximum adhesion to your substrates. This pressure should be applied in a rolling fashion. A hand roller or mechanical presser are the preferred methods. The pressure on the bond line must be a minimum of at least 10N/cm².

Storage & Shelf life

Please make sure that the tape is stored in its original packaging, in a dry place and at a preferable temperature between 4 °C and 38 °Celsius. When the tape is stored under the proper conditions, the tape has a shelf life of 18 months.

*Important Information

All technical data in this product data sheet are based on AFTC's experience and external testing institutes. These values are representative of the overall performance. These data sheets are NOT to be used for specification purposes or for your own specific application. It is your responsibility to test whether the tape is suitable for your application or project. AFTC will NOT be held liable for any information provided on this data sheet.

You must follow the rules and regulations that are applicable in the state, county or country where the AFTC product(s) are being used. If you have any questions regarding the use of the AFTC SilverTape acrylic foam tapes, please contact our technical sales team. For questions on the standard warranty, please review our standard delivery terms and conditions. For all other warranties, please review all documents that should have been agreed to in writing prior to the sale between AFTC and the customer. SilverTape® is a brand name of AFTC.